



Air Starters

ST600 Series

#1 Starter in the mining industry —
for use with air only



For engine displacement of: Diesel—1000 to 5000 CID (16 to 80 liters)
Carburated—2000 to 10,000 CID (32 to 160 liters)

Features/Benefits

- Powerful 67 hp turbine motor uses no external lubrication
- Extended pilot for easier installation
- Offset pre-engaged ports for greater fitting positioning
- Quiet operation turbine motor requires no muffler
- Smooth pre-engagement for limited ring gear wear
- 39 lb (17.7 kg) weight makes it the lightest starter in its class

Versatile

- Left- or right-hand rotation available
- 8 orientation options
- 30-150 (2.1-10.3 bars) psi operation



An **ST650BP03R31** starter is shown being mounted on a CAT3512 used on a mine haul truck.



An **ST650BP03R31** starter is shown mounted on a Detroit Diesel 12V-149R.



ST600 Series DIMENSIONS

Weight lbs (kg)	
ST600	39 (17.7)

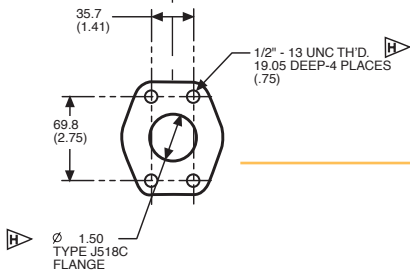
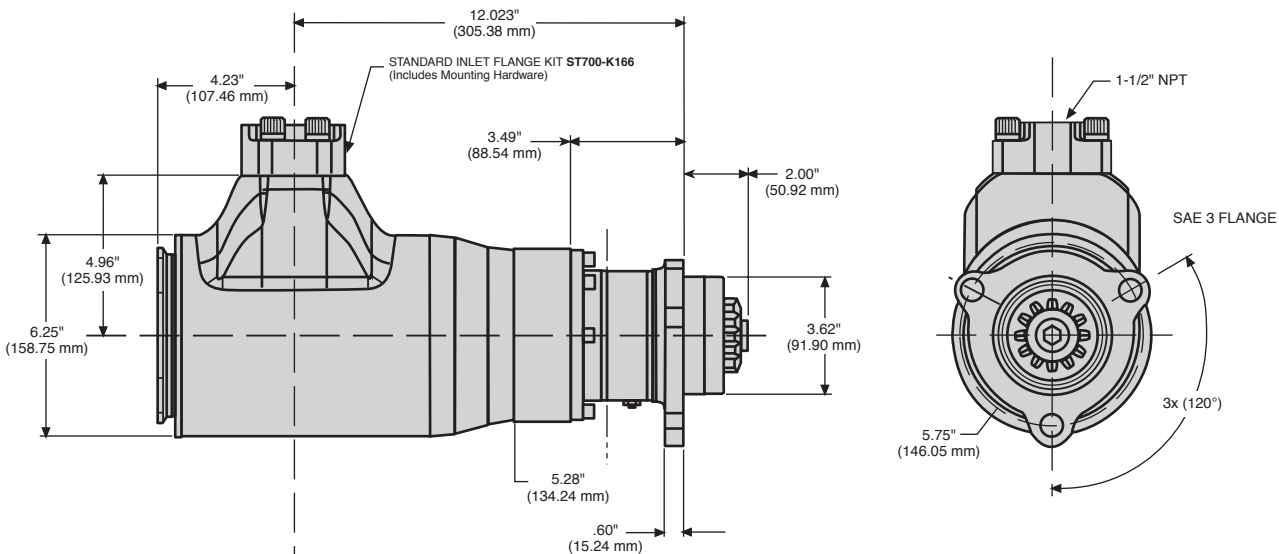

Inlet Flange Kit (ST700-K166) DIMENSIONS

Weight lbs (kg)	
ST700-K166	4.5 (2.0)



ST600 Series

ST650B Performance Information

Pressure PSI (bar)	Breakaway Torque ft-lb (Nm)	Speed @ Max HP RPM	Max Power HP (kw)	Flow @ Max HP SCFM (L/s)
90 (6.2)	155 (210)	2300	34 (25)	850 (401)
120 (8.3)	225 (305)	2350	50 (37)	1150 (543)
150 (10.3)	260 (352)	2600	65 (49)	1450 (684)

ST699B Performance Information

Pressure PSI (bar)	Breakaway Torque ft-lb (Nm)	Speed @ Max HP RPM	Max Power HP (kw)	Flow @ Max HP SCFM (L/s)
30 (2.1)	110 (149)	1950	20 (15)	600 (283)
60 (4.1)	195 (264)	2200	41 (31)	1150 (543)
90 (6.2)	290 (393)	2400	67 (50)	1700 (802)

NOTE: Overtorque safety clutch set between 330 to 440 ft-lb (447 to 596 Nm)

ST650 Number of Starts per Tank

(Assuming 2-Second Crank Time @ 90 PSI)

Max Tank Pressure (psi)	300	6	7	9	10	12	13	15	16	20	Max Tank Pressure (bar)	
	270	5	7	8	9	10	12	13	14	18		
	240	4	6	7	8	9	10	11	12	16		
	210	4	5	6	7	7	8	9	10	14		
	180	3	4	4	5	6	7	7	8	12		
	150	2	3	3	4	4	5	6	6	10		
	120	1	2	2	3	3	3	4	4	8		
	90	1	1	1	1	1	2	2	2	6		
		80	100	120	140	160	180	200	220			
		302	378	454	529	605	680	756	832			
	Tank Size									Gallons Liters		

ST600 Genuine Ingersoll-Rand Replacement Kits

Tune Up Kit Part Number	Description
ST600-TK1	ST600 Starter Tune Up Kit
ST600-SK1	ST600 Starter Seal Kit

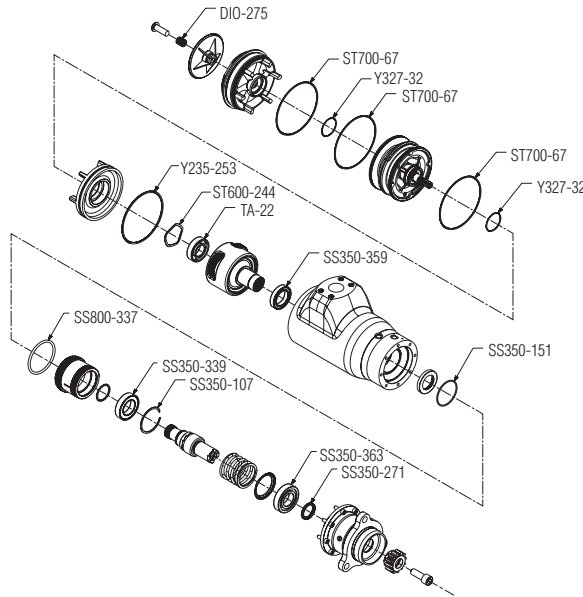

Exploded View of ST600-TK1 Part Location

ST600 Series Accessories

See catalog pages J-1 to J-18 for detailed Accessory information.

IR Part #	Description	Picture	IR Part #	Description	Picture
1 150BMP-1051B	1/4" 12 V Solenoid Valve		6 150BMP-1064	1/8", 150 psi Pressure Gauge	
2 150BMP-2451B	1/4" 24 V Solenoid Valve		7 ST900-267-24	1-1/2" Strainer (300 Mesh)	
3 SMB-618	Push Button Valve		8 ST900-266-24	1-1/2" Strainer Element (300 Mesh)	
4 SRV150	1-1/2" Relay Valve		9 150BMP-1056	1/2" Check Valve	
5 150BMP-1058	Gladhand		10 150BMP-1067	1/2" Drain Valve	

Red item numbers correspond to numbers in diagrams on page C-5.

ST600 Series

ST600 Diagram for a Typical Stationary Installation: Pre-engaged

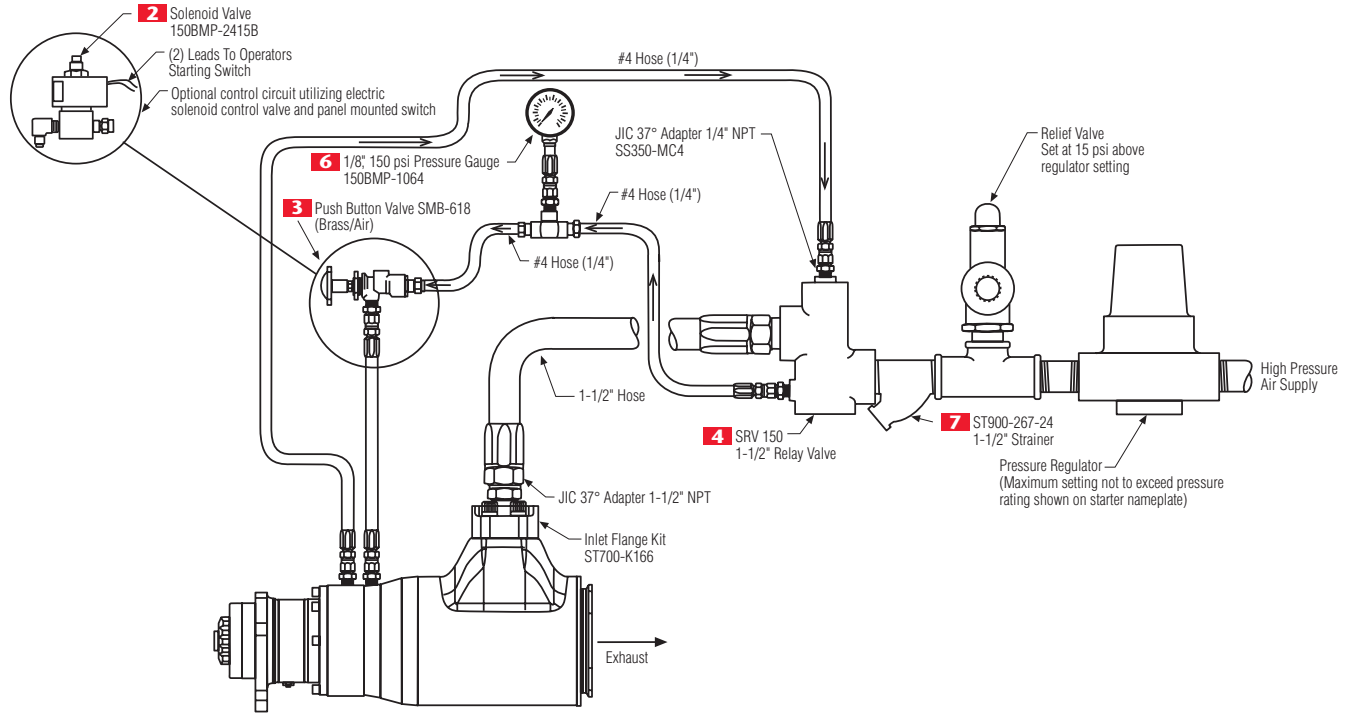

ST600 Diagram for a Typical Vehicular Installation: Pre-engaged

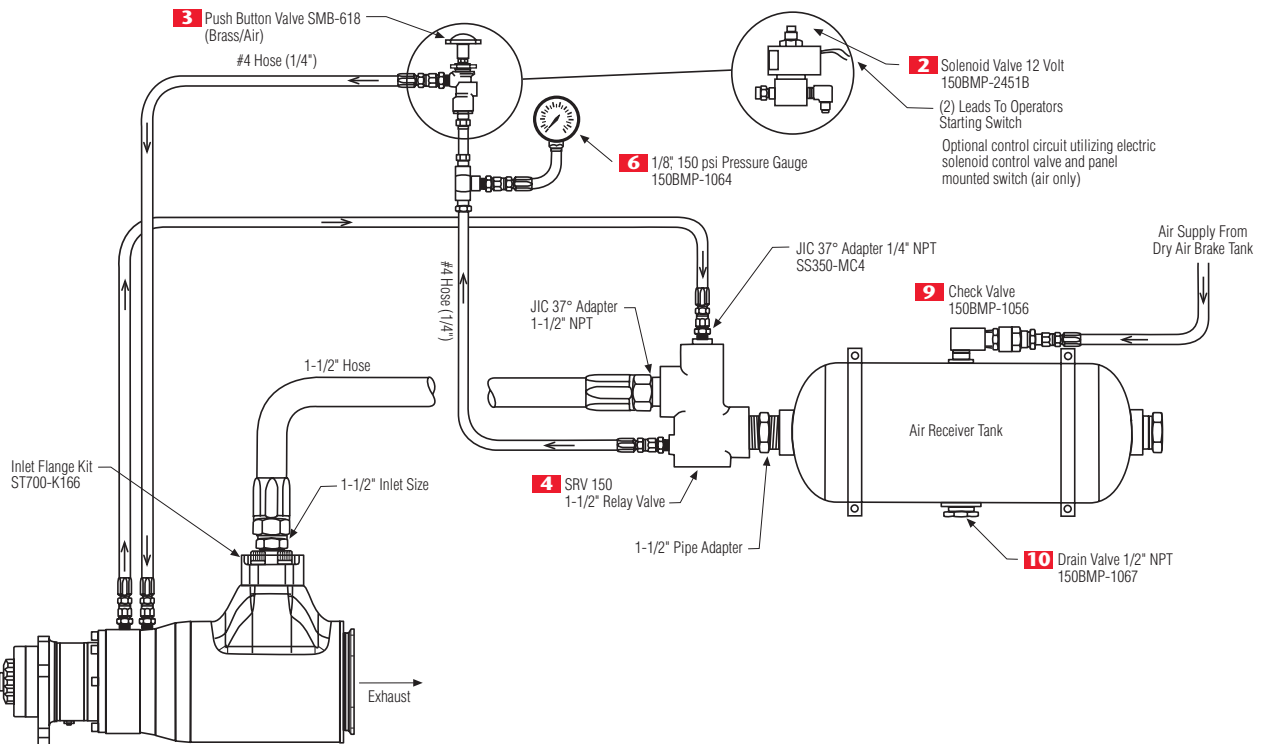



ST600 Series Air Starters

Bold Model Numbers indicate that a remanufactured model is available with the same part number (add an "R" to the number).

Most Obsolete Units ▶

ST600 Series Crossover Model Numbers

ST600 Available Units	ST900 Crossovers	ST700 Crossovers	SS800 Crossovers	Obsolete Units	Obsolete Units	Obsolete Units	Obsolete Units
ST650BP03R31	ST950BP03R31	ST750GBDP03R31	SS815GB03R31	SS800GB03R31	SS660RB991A01	SM450RB991A01	20BMB41RH-1
ST650BP03L31	ST950BP03L32	ST750GBDP03L32	SS815GB03L32	SS800GB03L32	SS660LB991A02	SM450LB991A02	20BMB47LH-4
ST650BP03R91		ST750GBDP03R91	SS815GB03R91	SS800GB03R91	SS660RB991A08		

This chart is a condensed list of engines that can be cranked with an IR starter. For a complete list, please contact IR.

ST600 Series Engine Selection Guide

Manufacturer	Engine	CID	Liter	CYL	Type	Turbine Starter
CATERPILLAR	3508	2105	34.5	8	Diesel	ST650BP03R31
	3512	3158	51.8	12	Diesel	ST650BP03R31
	3516	4210	69	16	Diesel	ST650BP03R31
	D-353	1473	24.1	6	Diesel	ST650BP03R31
	D-364	1662	27.2	8	Diesel	ST650BP03R31
	D-399	3927	64.4	16	Diesel	ST650BP03R31
CUMMINS	K19 SERIES	1150	18.8	6	Diesel	ST650BP03R31
	K38 SERIES	2300	37.7	12	Diesel	ST650BP03R31
	QSK45	2746	45	12	Diesel	ST650BP03R31
	QSK60	3660	60	16	Diesel	ST650BP03R31
	QST30	1861	30	12	Diesel	ST650BP03R31
DETROIT DIESEL	12V-92	1104	18.1	12	Diesel	ST650BP03R31
	12V-149	1788	29.3	12	Diesel	ST650BP03R31
	16V-149	2384	39.1	16	Diesel	ST650BP03R31
	16V-71	1136	18.6	16	Diesel	ST650BP03R31
	16V4000		60	16	Diesel	ST650BP03R31
WAUKESHA	12VAT25D	10784	176.7	12	Diesel	2-ST650BP03R31
	6AT25D	5392	88.4	6	Diesel	ST650BP03R31
	F2896D	2894	47.4	6	Diesel	ST650BP03R31
	F3335D	3335	54.7	6	Diesel	ST650BP03R31
WHITE ENGINES	DNX-V8C	1348	22.1	8	Diesel	ST650BP03R31
	DNX-V8D	1468	24.1	8	Diesel	ST650BP03R31

ST600 SERIES MODEL CODING

ST6 50 B P 03 R 31

